



Tubing Drain Performance

1.0 Introduction

This document provides a performance and strength comparison of Hawkeye Industries Inc. (Hawkeye's) tubing drains and other similar sleeve-activation drains on the market. Additionally, it highlights the degree to which Hawkeye drains meet the dimensional requirements for tubing couplings, and provide an overview of our testing procedure.

2.0 Reference Materials

This document makes reference, directly or implied, from the following documents:

API 5B:1996

Specification for Threading, Gauging, and Thread Inspection of Casing, Tubing and Line Pipe Threads (US Customary)

API 5CT:2006 / ISO 11960:2004

Specification for Casing and Tubing

Additionally, all dimensions indicated for competitor products are either measured dimensions from complete parts, or culled from publicly available information, and are subject to change due to manufacturing variations.

3.0 Design Features

Hawkeye's tubing drains are of the sleeve-activation type: A sleeve, which is part of the pressure containment envelope of the drain, covers the drainage ports in the body and secured by frangible fasteners (shear screws). When the pressure in the drain exerts enough force to yield the shear screws, the sleeve moves along the body of the drain to reveal the drain ports, allowing the contents of the tubing string to drain out.

3.1 Elongated Drain Ports

Hawkeye's tubing drain feature elongated drain ports, setting them apart from the round ports of other sleeve-activated drains. Elongated ports increase drainage flow area, reducing the total number of ports required to match the tubing flow area. The elimination of superfluous ports from the body of the tubing drain increases the tensile strength of the drain by minimizing the material removed from the load-bearing cross-section.

3.2 Mechanical Activation

Hawkeye's tubing drain feature mechanical activation capabilities. A groove cut into the sleeve of the drain allows, with the use of activation tooling available from Hawkeye, activation of the tubing drain with only a shop press.

3.3 Long Clearance Bevels

The Body and Sleeve of the Hawkeye Tubing drain sport 20° clearance bevels.

4.0 Dimensional Conformance

Tubing drains manufactured by Hawkeye conform to the Coupling dimensions specified in API 5CT – 2005 for External Upset (EU) Thread and Coupled (T&C) Tubing.

5.0 Drain Area

Hawkeye's drain has larger drain area compared to competitor drains, both in gross drainage area, but also as a percentage of the tubing flow area (Table 5.1).

Tubing Size (EUE)	Hawkeye		Competitor		Hawkeye Area Advantage (%)
	Port Area (in ²)	% of Flow Area	Port Area (in ²)	% of Flow Area	
2-3/8	3.1	98%	2.4	72%	27%
2-7/8	3.8	81%	2.8	58%	38%
3-1/2	4.6	65%	3.1	45%	45%
4-1/2	6.0	49%	6.0	49%	0%

Table 5.1 Drainage Area Comparison

Hawkeye Drains exceed competitor drains in both total port area, as well as port area as a percentage of tubing flow area.

The increased area of the Hawkeye drain allows the tubing string to drain faster in comparison to other drains with limited drainage area.

6.0 Performance in Torsion

Using fewer elongated ports to meet the required drainage area increases the tensile strength of the tubing drain by reducing the material removed from the load bearing cross section.

Finite element analysis, using the maximum make-up torque of L80 tubing as listed in Table 6.1, yields the results shown in figures 6.2 through 6.5, which confirm torsional performance of the tubing drain bodies with elongated drain ports.

In general, the o-ring and shear screw grooves, and not the elongated drain ports tend to be the limited feature in terms of torsional strength.

Size (EUE)	Weight (lb/ft)	M/U Torque (ft-lb)
2-3/8	4.7	2200
2-7/8	6.5	2810
3-1/2	9.3	3910
4-1/2	12.5	4930

Table 6.1 L80 Make-up Torques

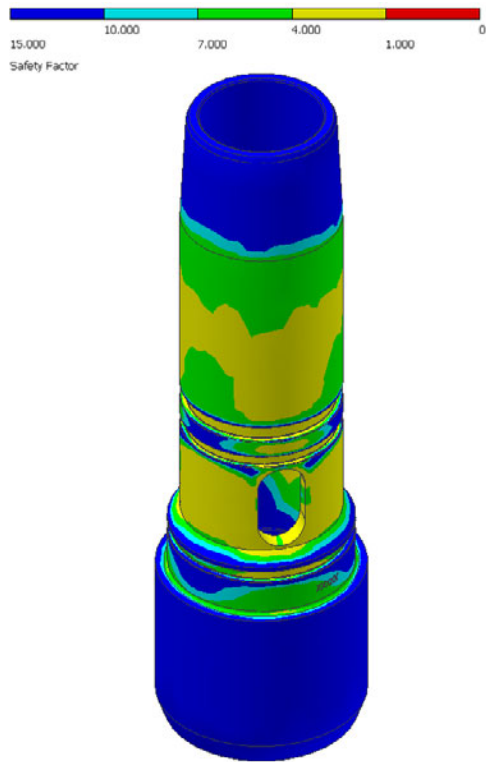

Figure 6.2 2-3/8: Safety Factor at 2200 ft-lb
Cooler colours indicate higher safety factor. Red areas indicate yielding.

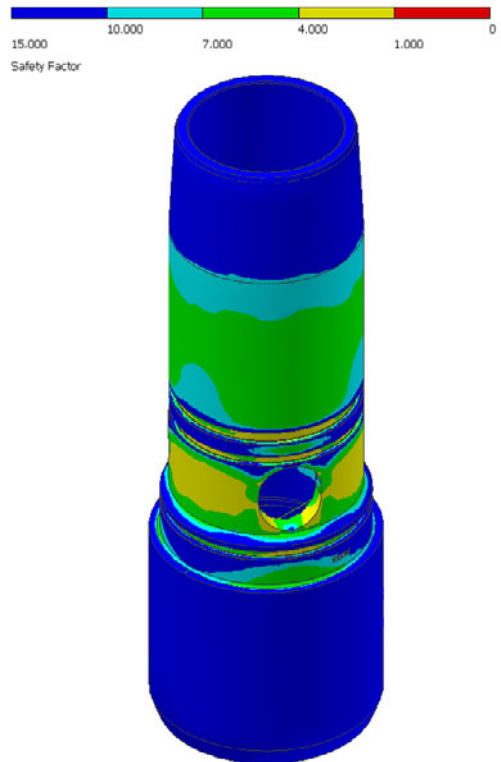

Figure 6.4 3-1/2: Safety Factor at 3910 ft-lb
Cooler colours indicate higher safety factor. Red areas indicate yielding.

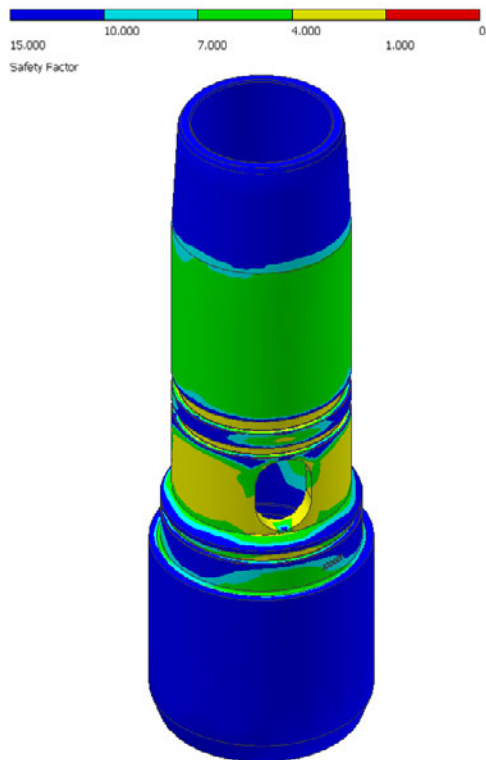

Figure 6.3 2-7/8: Safety Factor at 2810 ft-lb
Cooler colours indicate higher safety factor. Red areas indicate yielding.



Figure 6.5 4-1/2: Safety Factor at 4930 ft-lb
Cooler colours indicate higher safety factor. Red areas indicate yielding.

7.0 Testing

Hawkeye purchases shear screw material in mill-runs to ensure consistency of mechanical properties within the manufacturing run. Although material test reports accompany this material, this data is not suitable for the testing and qualification of the complete drains, thus Hawkeye performs extensive in-house testing prior to large-scale screw manufacturing.

Testing consists of a standard tubing drain, EUE test couplings and a high-pressure hydraulic pump. Using the shear screws manufactured from the new batch of material to secure the sleeve to the body, engineers repeatedly pressurize the apparatus and record the activation pressure.

This data provides the basis for making any adjustments to the critical design points of the screws to ensure activation pressures consistent with both published data, and previous manufacturing runs.

Engineers test the drains following adjustment, and if required make further refinements, continuing in this until activation pressures are within +10% / -5% of published values. This ensures backwards compatibility, allowing the use of new screws in older, refurbished drains with consistent activation values.

Quality control releases the screw material for large-scale manufacture of shear screws upon successful completion of the activation pressure testing.

Although the shear screw design and test data are proprietary, we welcome customers/end users to witness testing.