



Critical Flow Prover Operating Guide

1.0 Introduction

The critical flow prover (CFP) device provides a means to determine gas flow rate, Q , using principles of adiabatic, frictionless compressible flow in the critical, or choked, condition.

2.0 Principles of Operation

A compressible fluid traveling at subsonic velocity through a duct of constant cross section will increase velocity when passing through a region of reduced cross-sectional area (in this case, an orifice) to satisfy mass flow continuity. To satisfy conservation of energy, the fluid pressure at the obstruction decreases (i.e. Venturi effect).

Maximum velocity at the obstruction is limited by the rate at which pressure waves can propagate through the fluid (“the speed of sound”), and the flow will not exceed this velocity at the obstruction. Known as choked, or critical flow, the orifice velocity remains constant over a wide range of downstream pressure and temperature conditions. Since volumetric flow is proportional velocity, the volume flow rate of a choked flow can be determined based solely on upstream absolute pressure and temperature.

Critical flow will occur as the ratio of the obstruction flow area to the duct flow area approaches zero, and the ratio of upstream to downstream pressure for air, assumed to be an ideal gas, is 0.528^1 . That is, the downstream pressure must be 0.528 times the upstream pressure (or less) in order to have critical flow at the obstruction. For example, to have critical flow with an upstream pressure of 10 MPa, the downstream pressure must be 5.28 MPa or less.

Empirically, natural gas exhibits critical flow behavior with straight-edge orifice diameters less than 60% of the pipe diameter, and ratio of absolute downstream to absolute upstream pressure between 0.56 and 0.58. For example, a subsonic natural gas flow in a 50 mm pipe at 10 MPa will be critical through a 30 mm (or smaller) orifice, and downstream pressure of 5.6 MPa or less.

The critical flow prover device ensures choked flow over a wide range of downstream pressures, allowing the use of critical flow property relationships to determine flow rate. By using critical flow properties, variability as a result of fluctuating downstream conditions is negated, allowing flow rates to be computed based solely on upstream conditions.

3.0 Device Description

The Hawkeye Industries Critical Flow Prover consists of a tubular section, approximately 6 pipe diameters long, with a smooth inside diameter and standard 2 NPT connection on the upstream end. The opposite end features a recess, with an o-ring face-seal, for a 1/4 in. thick orifice plate, held in place by a knurled retention cap. Approximately one pipe diameter upstream of the orifice plate are a 1/2 NPT and 1/4 NPT pressure taps, suitable for gauge mounting and a thermowell.

4.0 Operating Information

4.1 Equation

The flow rate through the CFP is determined using the following equation:

$$Q = \frac{CP}{\sqrt{GT}} \quad (\text{eq. 1})$$

Where:

Q = Flow Rate ($10^3 \text{ ft}^3 / 24 \text{ hr}$ (aka Mcfh) or $10^3 \text{ m}^3 / \text{d}$)

C = Orifice Coefficient (empirically derived, see table 1)

P = Absolute Upstream Pressure (psi or MPa)

G = Specific Gravity of Gas (air = 1.0)

T = Absolute Upstream Temperature ($^{\circ}\text{R}$ or K)

Note: Equation 1 assumes a perfect gas, and does not account for deviations from Boyle’s Law behavior.

Table 1

Empirically Derived Orifice Coefficient				
* IMPERIAL AND METRIC (SI) UNITS *				
For 2 NPS [60.3 mm] Critical Flow Prover (2.00 in. [50.8 mm] bore)				
Orifice Diameter (in.)	(mm)	Coefficient, C (imperial)	Coefficient, C (metric)	Variance (%)
1/16	1.6	1.524	4.666	3.61
3/32	2.4	3.355	10.27	1.14
1/8	3.2	6.301	19.29	2.25
3/16	4.8	14.47	44.30	3.88
7/32	5.6	19.97	61.14	3.82
1/4	6.4	25.86	79.17	1.88
5/16	7.9	39.77	121.8	2.13
3/8	9.5	56.58	173.2	2.74
7/16	11.1	81.09	248.3	2.33
1/2	12.7	101.8	311.7	2.29
5/8	15.9	154	471.5	1.56
3/4	19.1	224.9	688.5	1.03
7/8	22.2	309.3	946.9	2.31
1	25.4	406.7	1245	2.09
1 1/8	28.6	520.8	1594	1.26
1 1/4	31.8	657.5	2013	3.61
1 3/8	34.9	807.8	2473	2.05
1 1/2	38.1	1002	3068	6.32

Tables 1 provides orifice coefficients for imperial units and metric (SI) units. The coefficients were derived from equation 1, using a known flow rate, Q , at a temperature of 60°F [519.67 °R] and downstream pressure of 14.4 psia.

4.2 Units:

When determining flow rate in imperial units ([Mcfh], or [$10^3 \text{ ft}^3/24\text{hr}$]) use the following units in equation 1:

¹ Eq. 9.32, White, F.M., (1999). *Fluid Mechanics*. New York: WCB McGraw Hill.

C: From Table 1.²
P: pounds per square inch [psi]
G: unitless
T: Rankine [$^{\circ}R$]

Likewise, to determine flow rate in metric, or SI units ($[10^3 m^3/d]$) use the following units in equation 1:

C: From Table 1.²
P: Megapascals [MPa]
G: unitless
T: Kelvin [K]

4.3 Absolute Temperature:

Thermodynamic calculations require use of absolute temperature in computations. In imperial units, absolute temperature is measure in Rankine ($^{\circ}R$), calculated using the following formula:

$$[^{\circ}R] = [^{\circ}F] + 459.67 \quad (\text{eq. 2})$$

Example: $60^{\circ}F = 519.67^{\circ}R$

Similarly in SI, absolute temperature is measured in Kelvin (K) and is calculated using the following formula:

$$[K] = [^{\circ}C] + 273.15 \quad (\text{eq. 3})$$

Example: $17^{\circ}C = 290.15 K$

4.4 Graphical Representation:

The flow rate, in $10^3 \text{ ft}^3/24\text{hr}$ (Mcfh), has been calculated at 14.4 psi and $60^{\circ}F$ [$519.67^{\circ}R$], and plotted on charts A1 through B4, with a line for each orifice size (listed on the chart margins). Chart series A is scaled to provide legible values for orifice diameters 1/4 in. and under, while the series B charts show full-scale flow values.

Similarly, the flow rates, in $10^3 m^3/d$ at 99.3 kPa and $16^{\circ}C$ [$289.15 K$] have been calculated, and plotted on charts C1 through D4, with a line for each orifice size (listed on the chart margins). Chart series C is scaled to provide legible values for orifice diameters 1/4 in. and under, while the series D charts show full-scale flow values.

5.0 Flow Charts

5.1 Scaled to 1/4 in. Orifice Plate Full Flow (Imperial Units):

Table A1:
Flow Rate vs. Upstream Pressure (100 psi),

Table A2:
Flow Rate vs. Upstream Pressure (500 psi),

Table A3:
Flow Rate vs. Upstream Pressure (1000 psi)

Table A4:
Flow Rate vs. Upstream Pressure (3000 psi)

5.2 Full Scale Flow (Imperial Units):

Table B1:
Flow Rate vs. Upstream Pressure (100 psi)

Table B2:
Flow Rate vs. Upstream Pressure (100 psi)

Table B3:
Flow Rate vs. Upstream Pressure (100 psi)

Table B4:
Flow Rate vs. Upstream Pressure (100 psi)

5.3 Scaled to 1/4 in. Orifice Plate Full Flow (Metric Units):

Table C1:
Flow Rate vs. Upstream Pressure (1 MPa)

Table C2:
Flow Rate vs. Upstream Pressure (5 MPa)

Table C3:
Flow Rate vs. Upstream Pressure (10 MPa)

Table C4:
Flow Rate vs. Upstream Pressure (20 MPa)

5.4 Full Scale Flow (Metric Units):

Table D1:
Flow Rate vs. Upstream Pressure (1 MPa)

Table D2:
Flow Rate vs. Upstream Pressure (5 MPa)

Table D3:
Flow Rate vs. Upstream Pressure (10 MPa)

Table D4:
Flow Rate vs. Upstream Pressure (20 MPa)

6.0 Schematic

6.1 Critical Flow Prover, DWG# CFP-200-GD

² Form 11-10, Page 3-2", Chandler Engineering Company (1959). Instructions: Critical Flow Prover – Bureau of Mines Type for Back Pressure Tests on Natural Gas Wells.

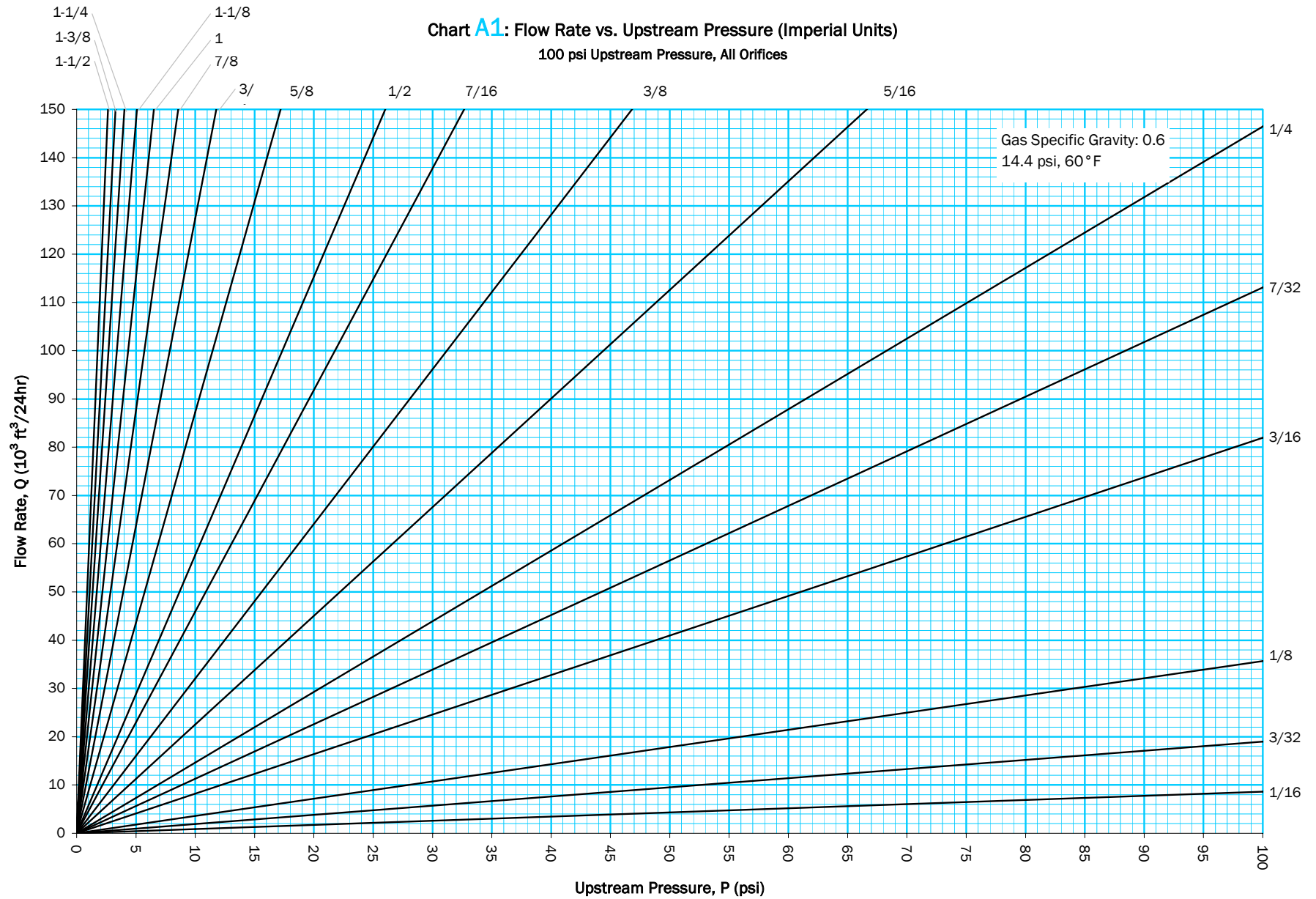

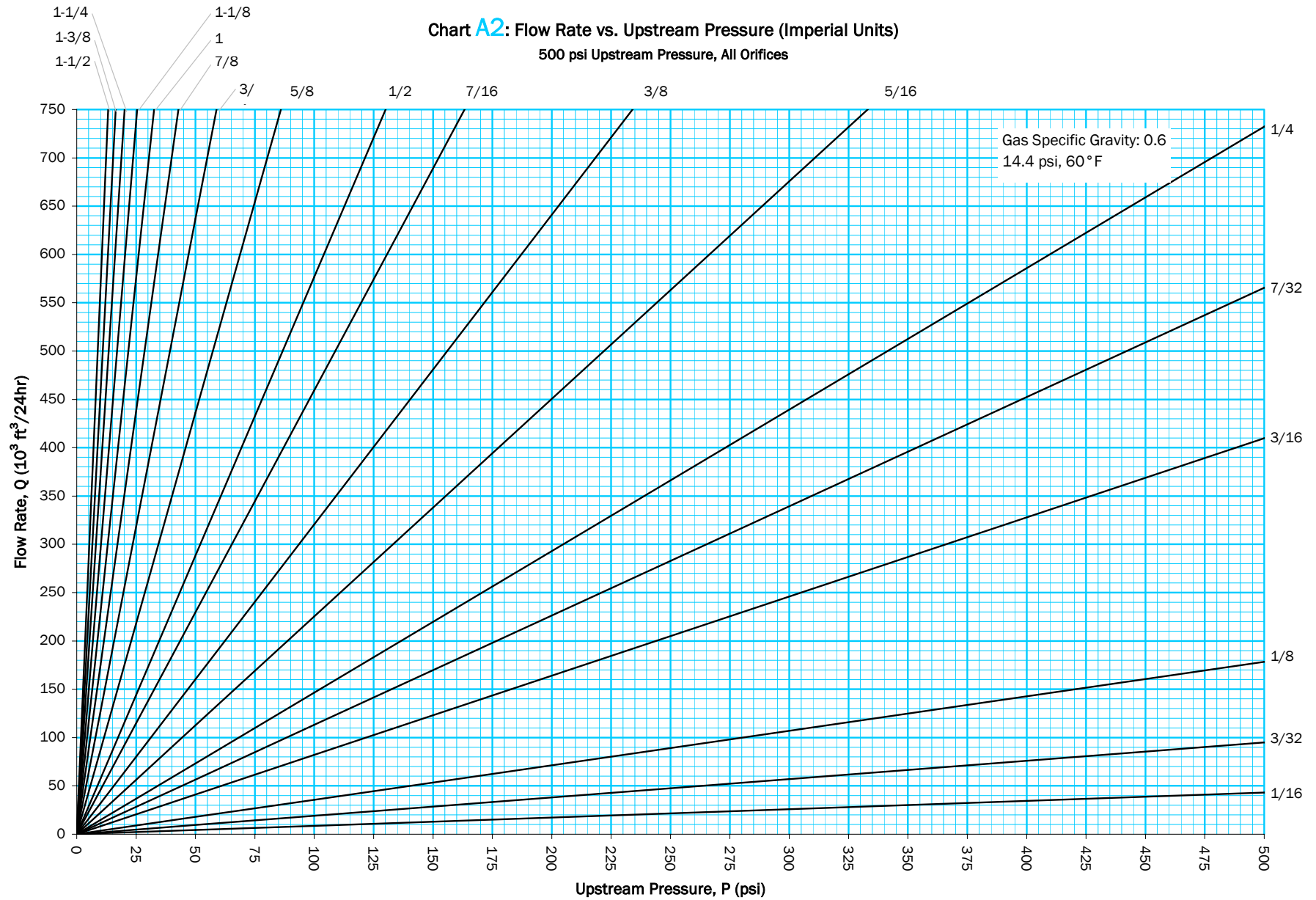

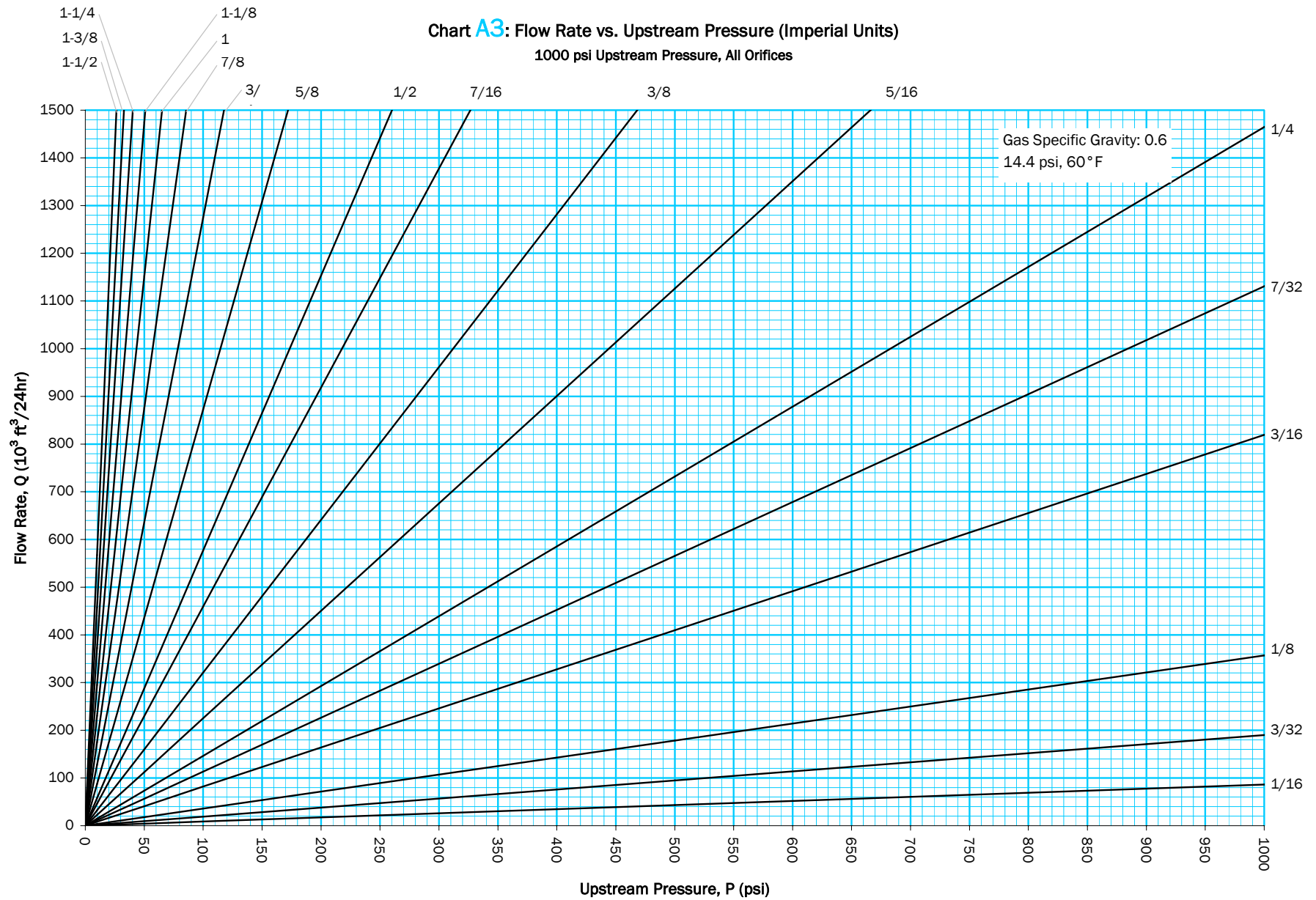

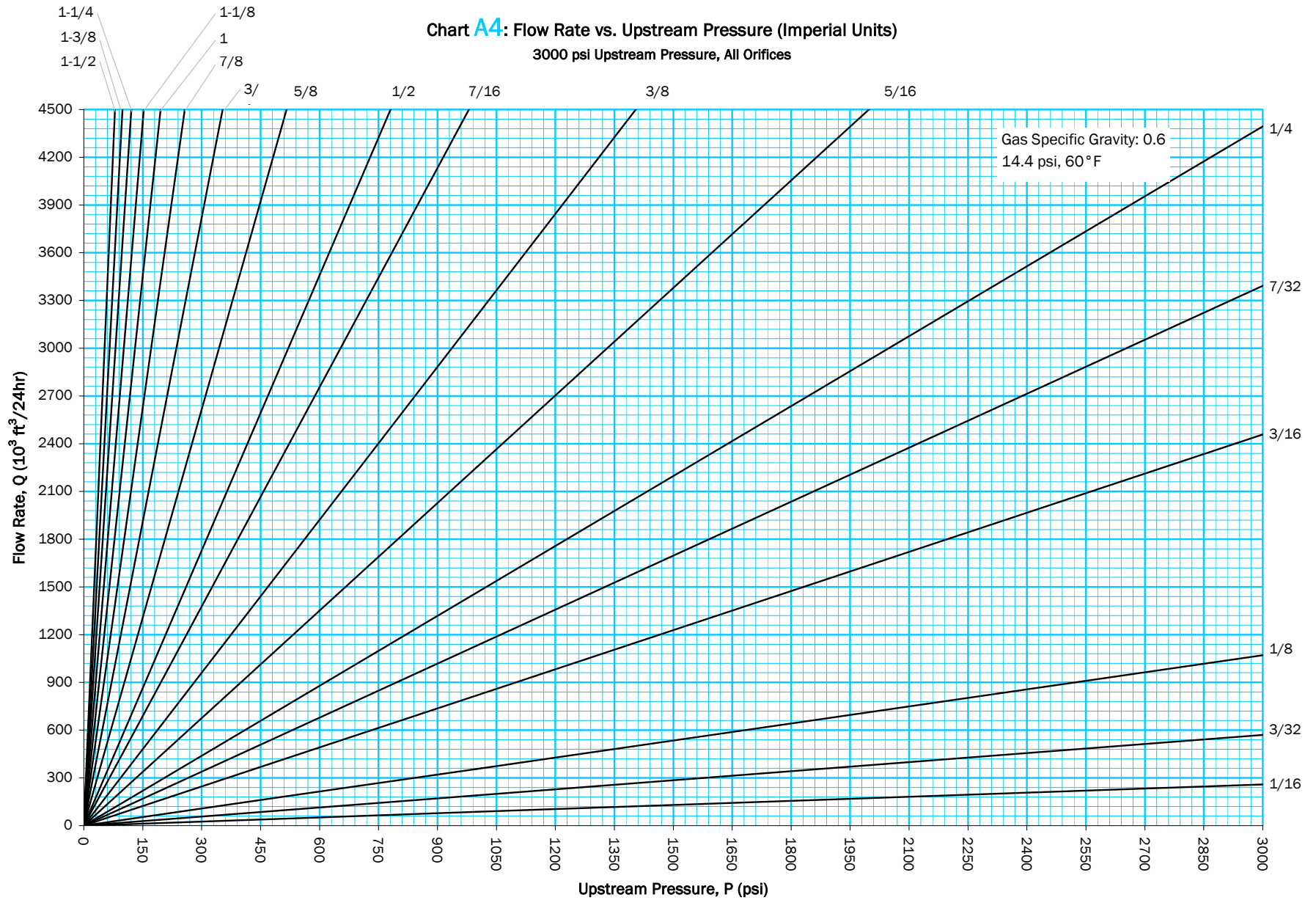



Chart B1: Flow Rate vs. Upstream Pressure (Imperial Units)
100 psi Upstream Pressure, Orifices 5/16 and Larger

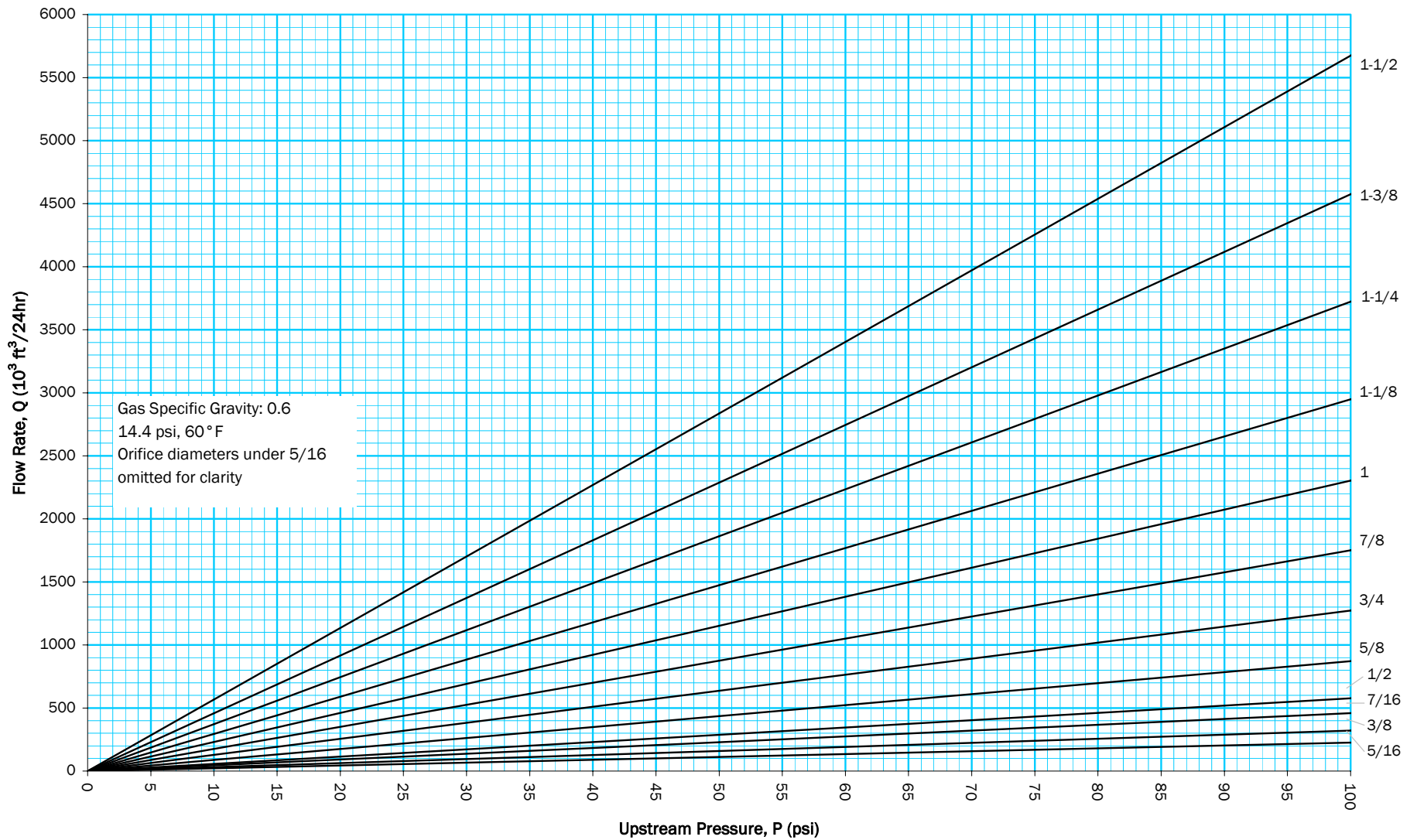



Chart B2: Flow Rate vs. Upstream Pressure (Imperial Units)
500 psi Upstream Pressure, Orifices 5/16 and Larger

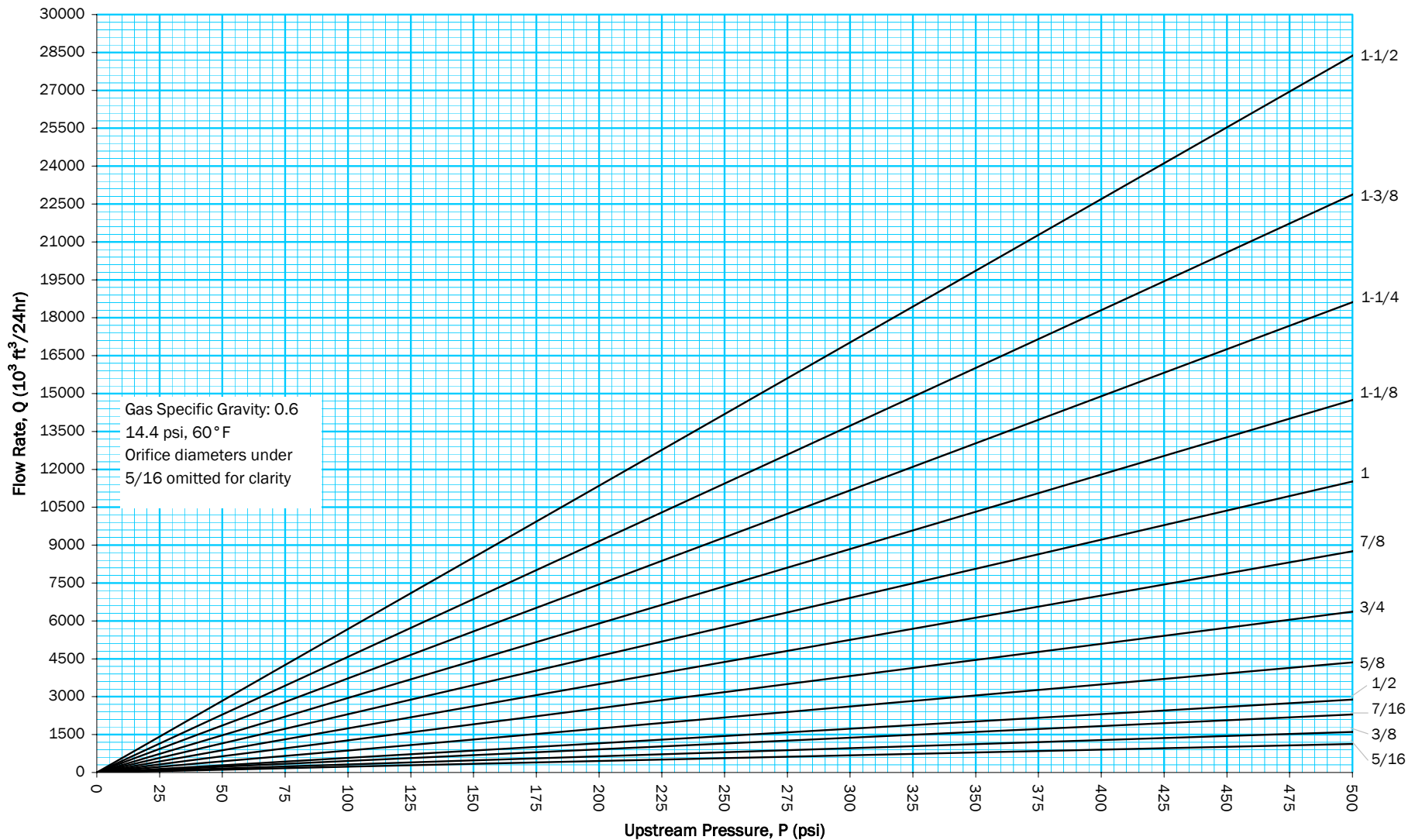



Chart B3: Flow Rate vs. Upstream Pressure (Imperial Units)
1000 psi Upstream Pressure, Orifices 5/16 and Larger

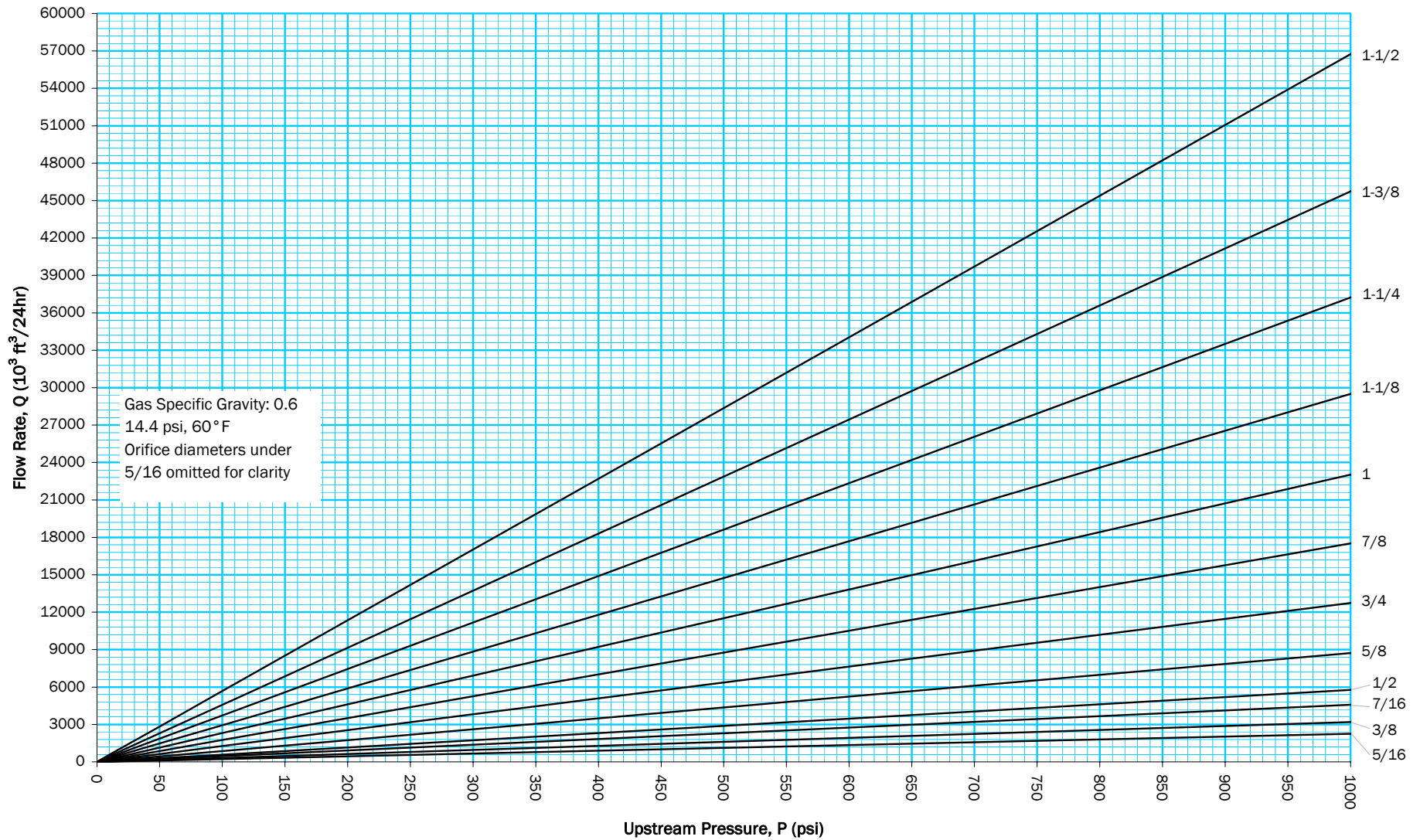
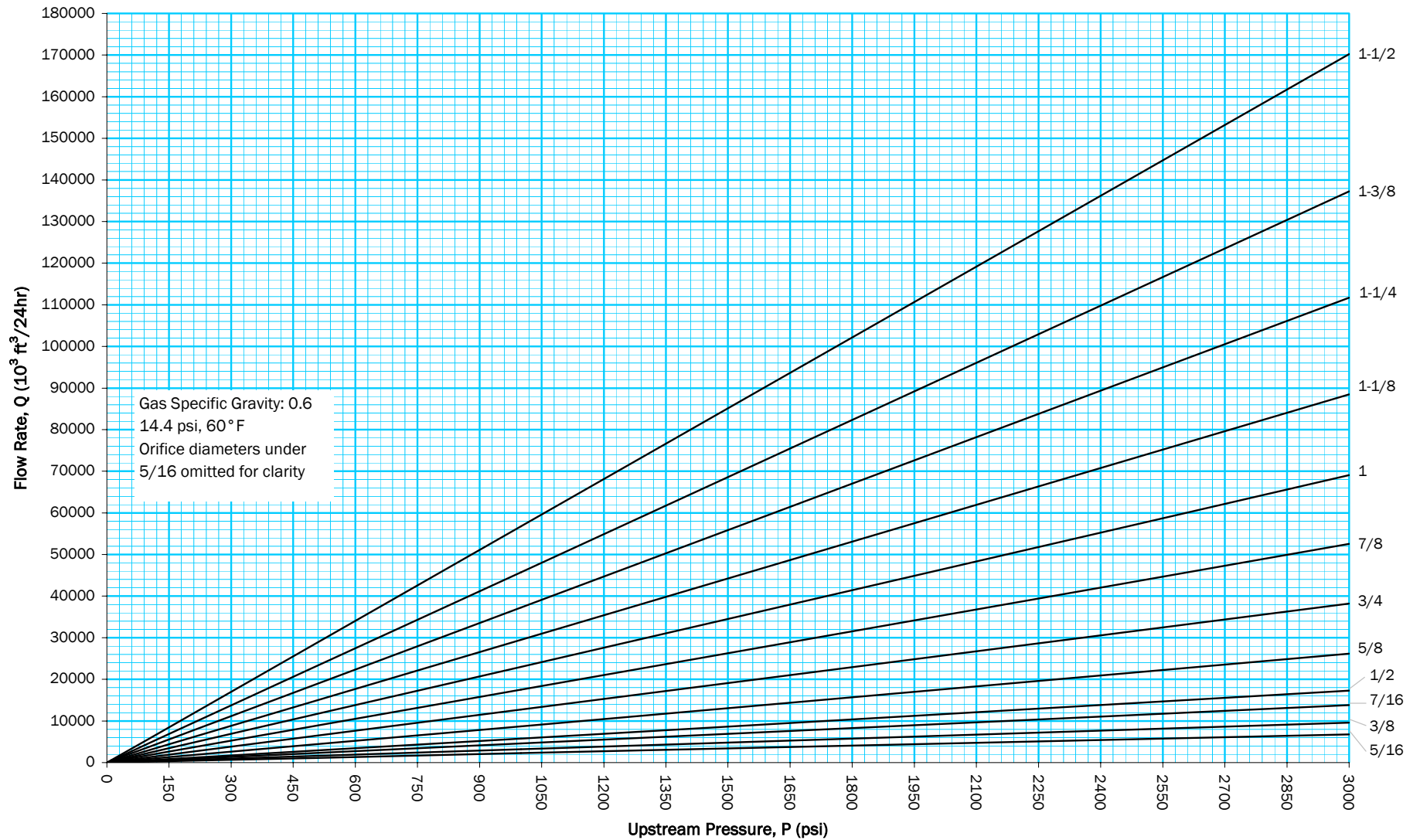
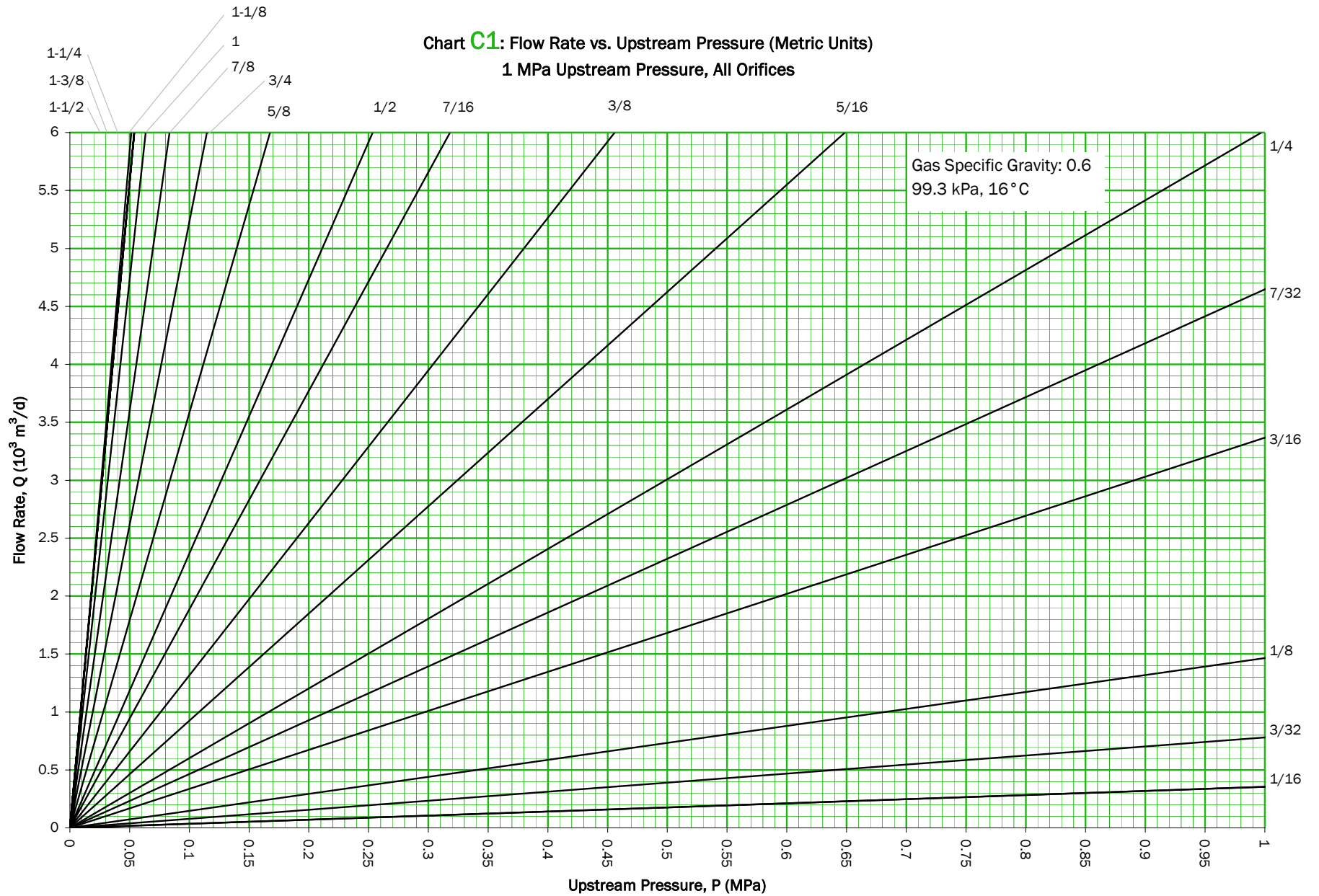
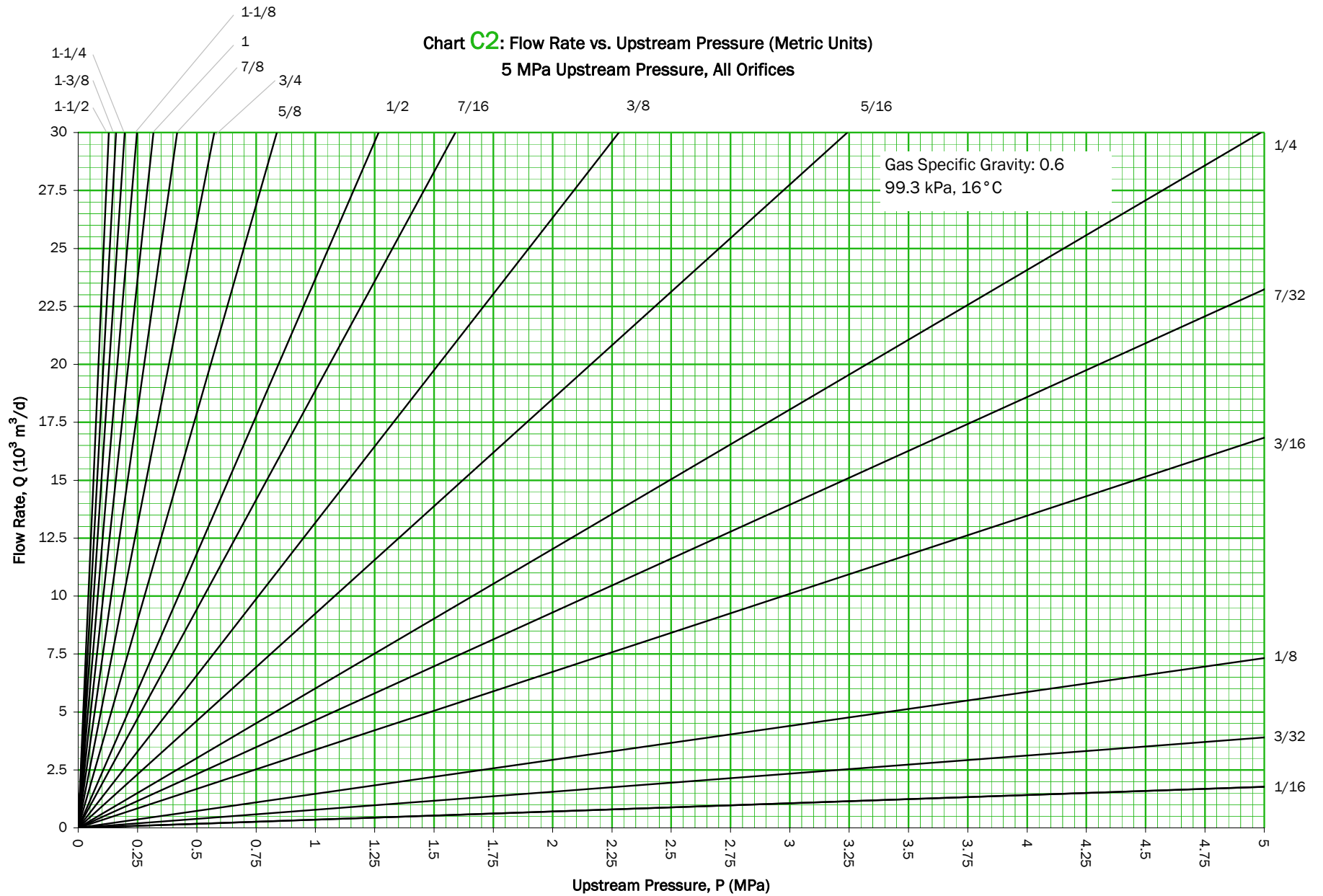

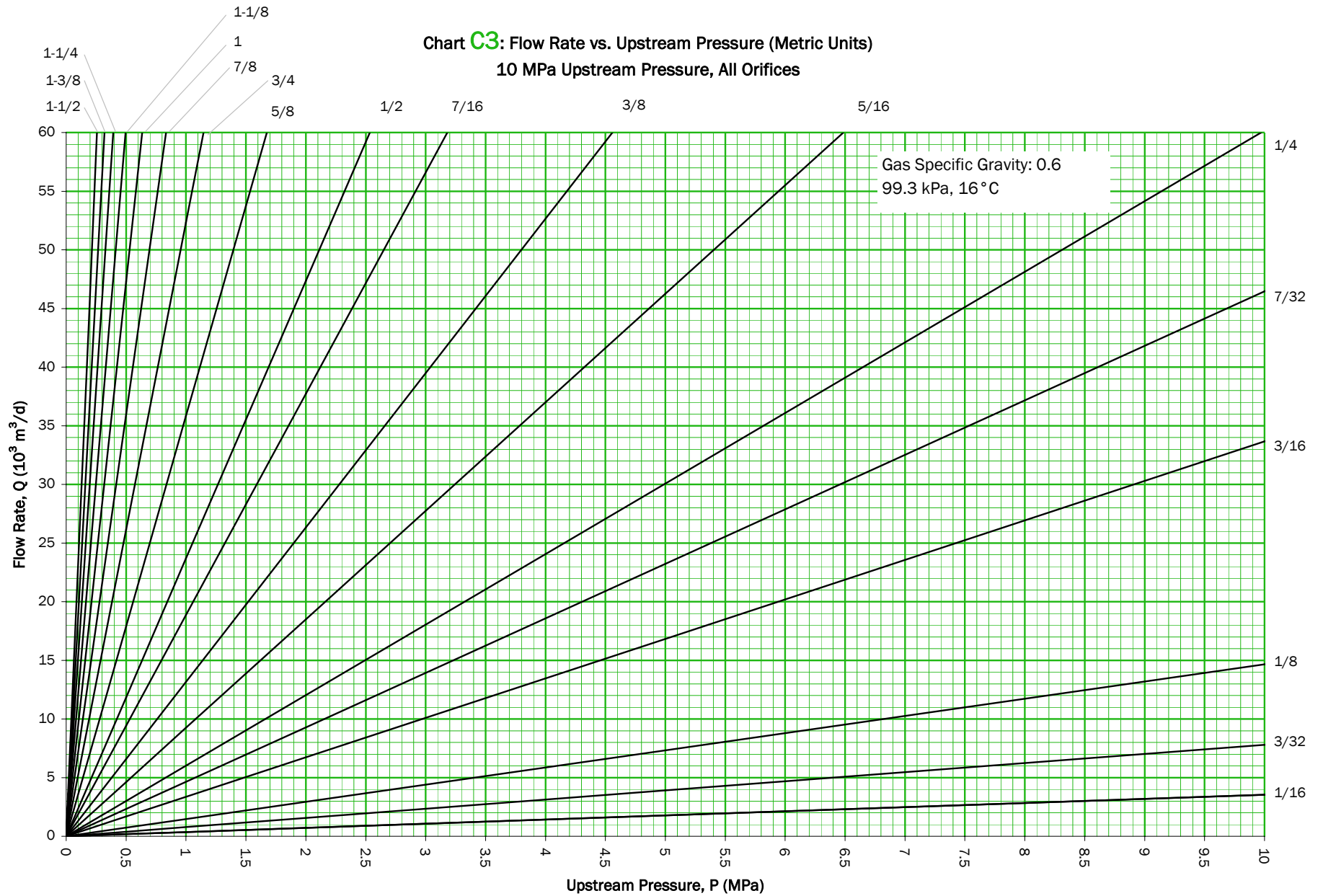

Chart B4: Flow Rate vs. Upstream Pressure (Imperial Units)
3000 psi Upstream Pressure, Orifices 5/16 and Larger









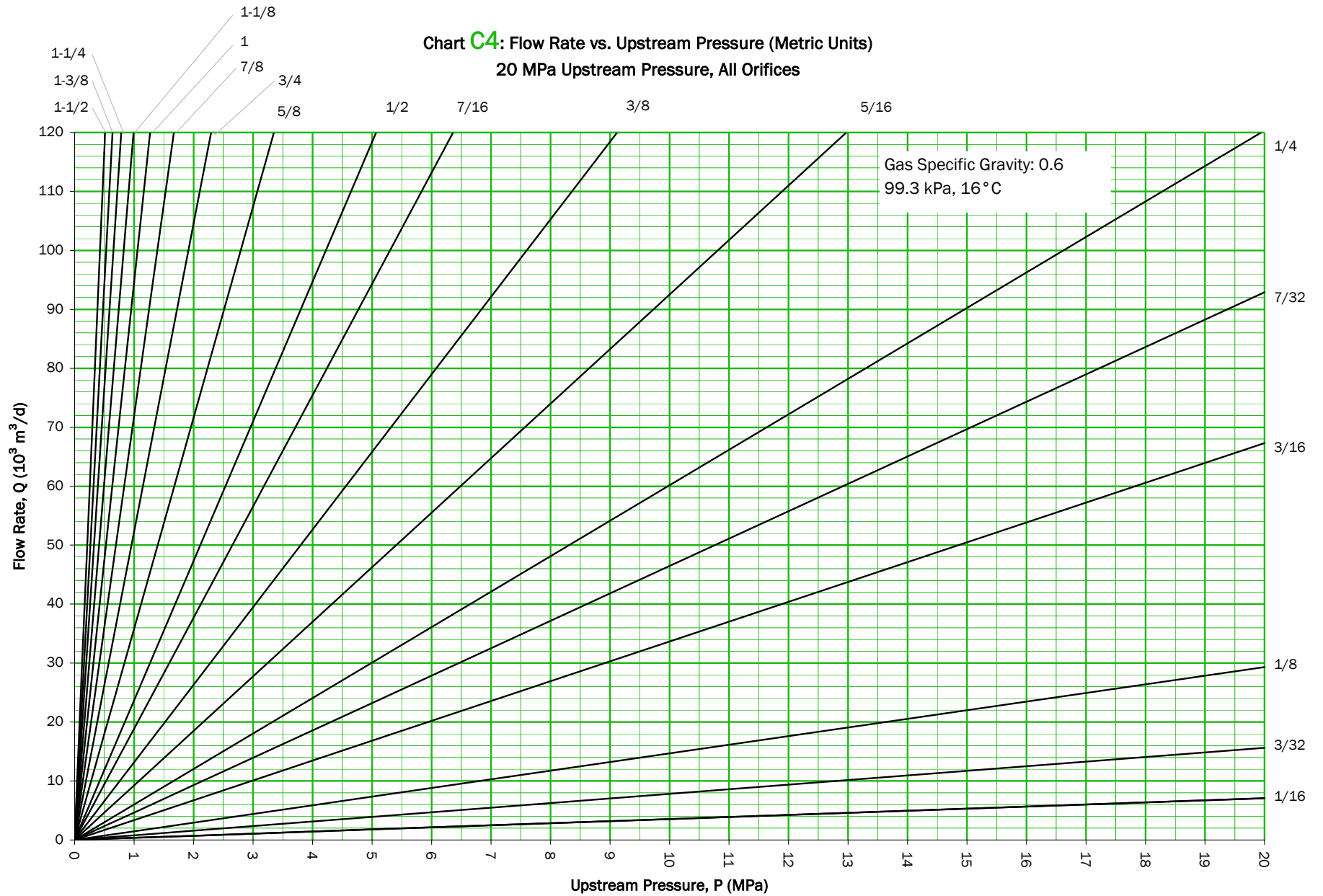



Chart **D1**: Flow Rate vs. Upstream Pressure (Metric Units)
1 MPa Upstream Pressure, Orifices 5/16 and over

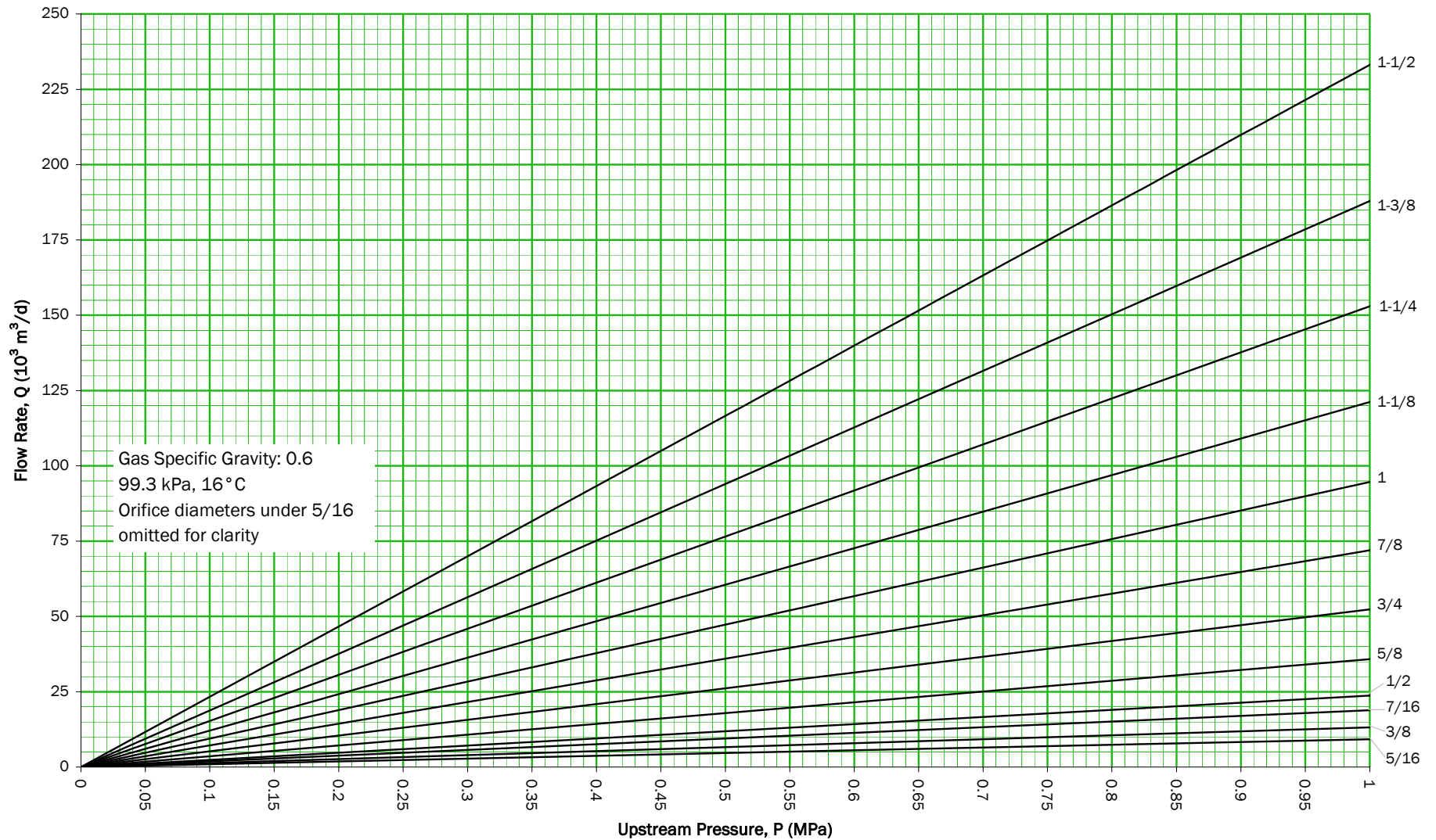



Chart **D2**: Flow Rate vs. Upstream Pressure (Metric Units)
5 MPa Upstream Pressure, Orifices 5/16 and over

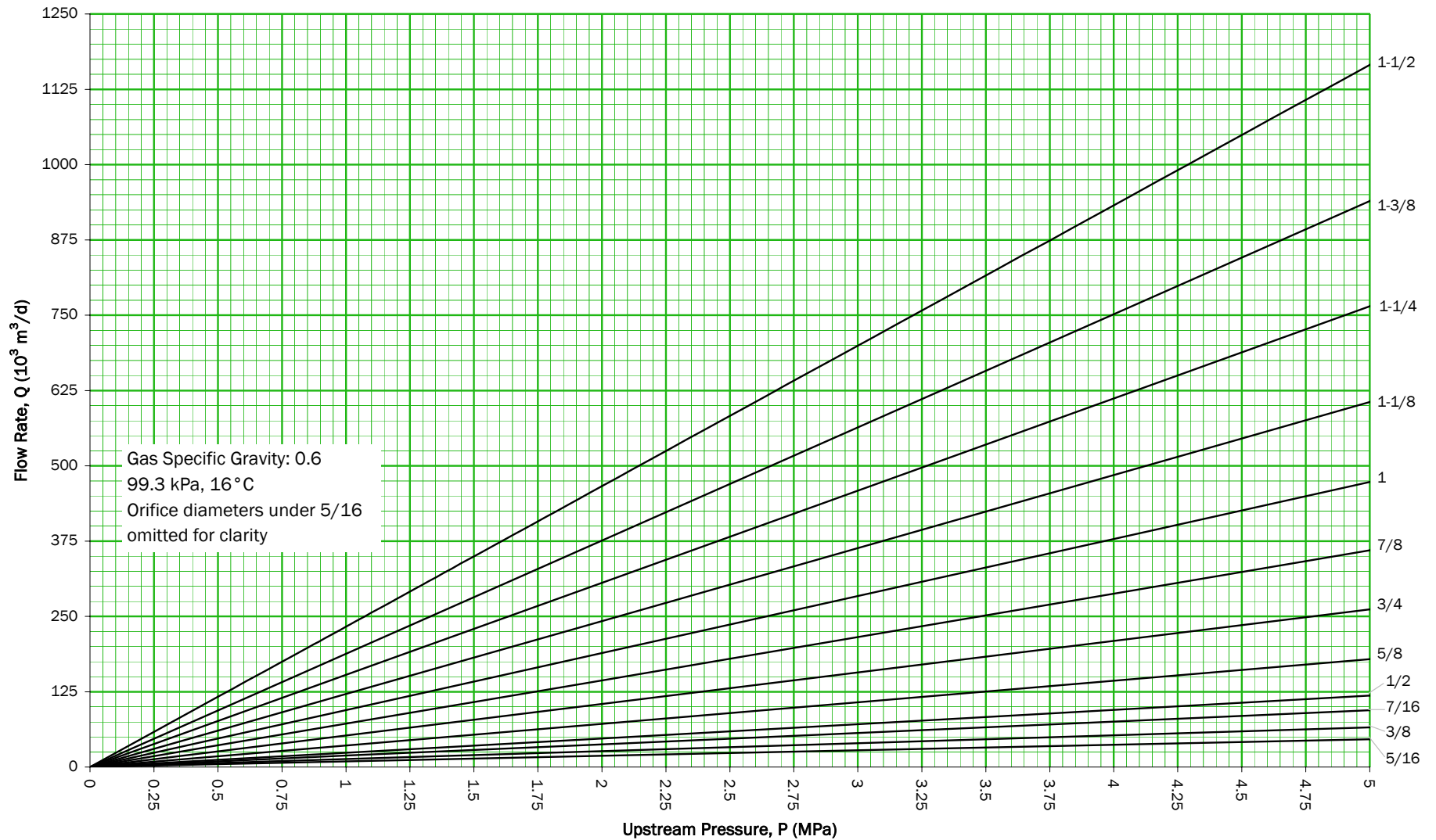



Chart **D3**: Flow Rate vs. Upstream Pressure (Metric Units)
10 MPa Upstream Pressure, Orifices 5/16 and over

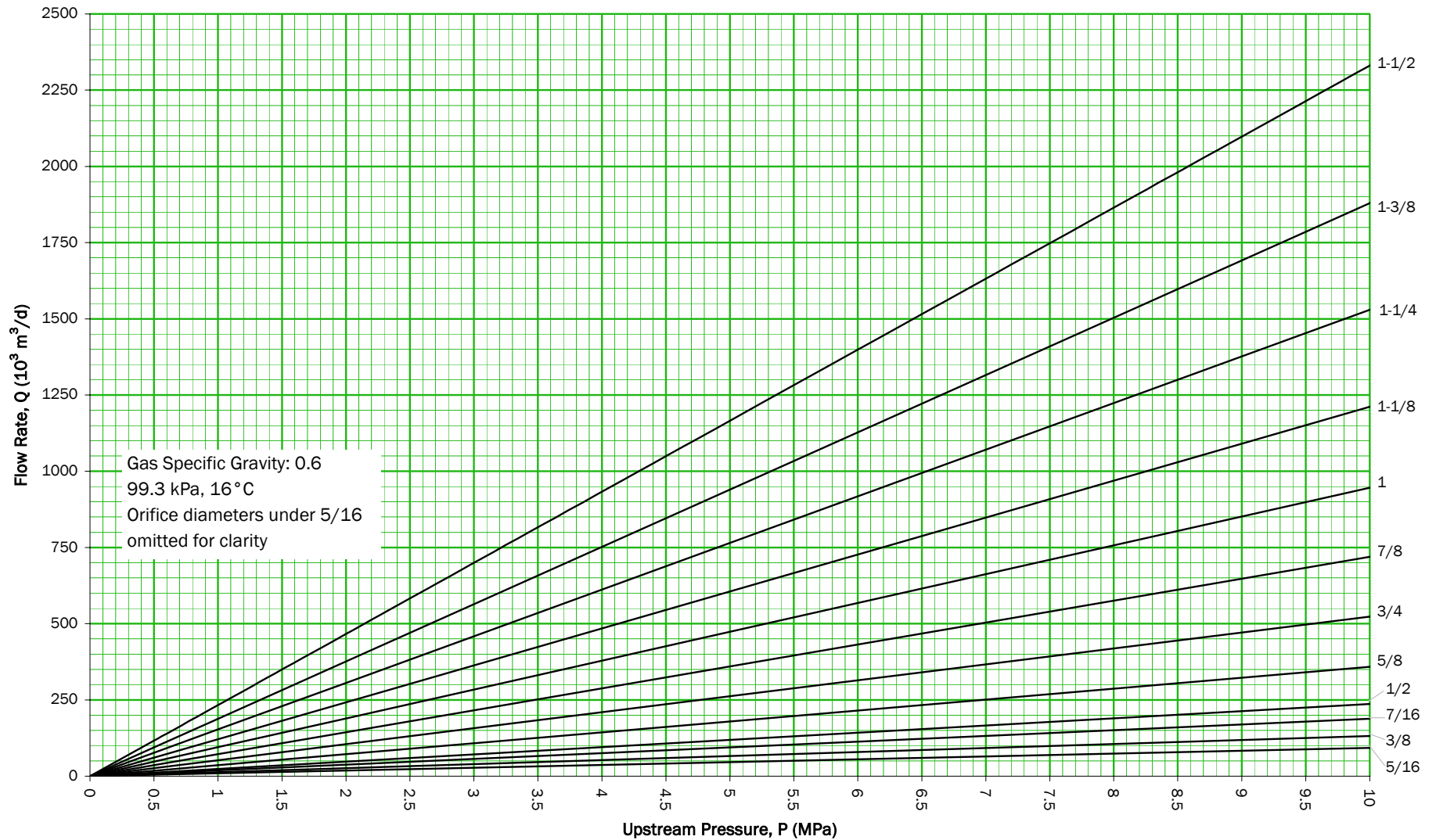
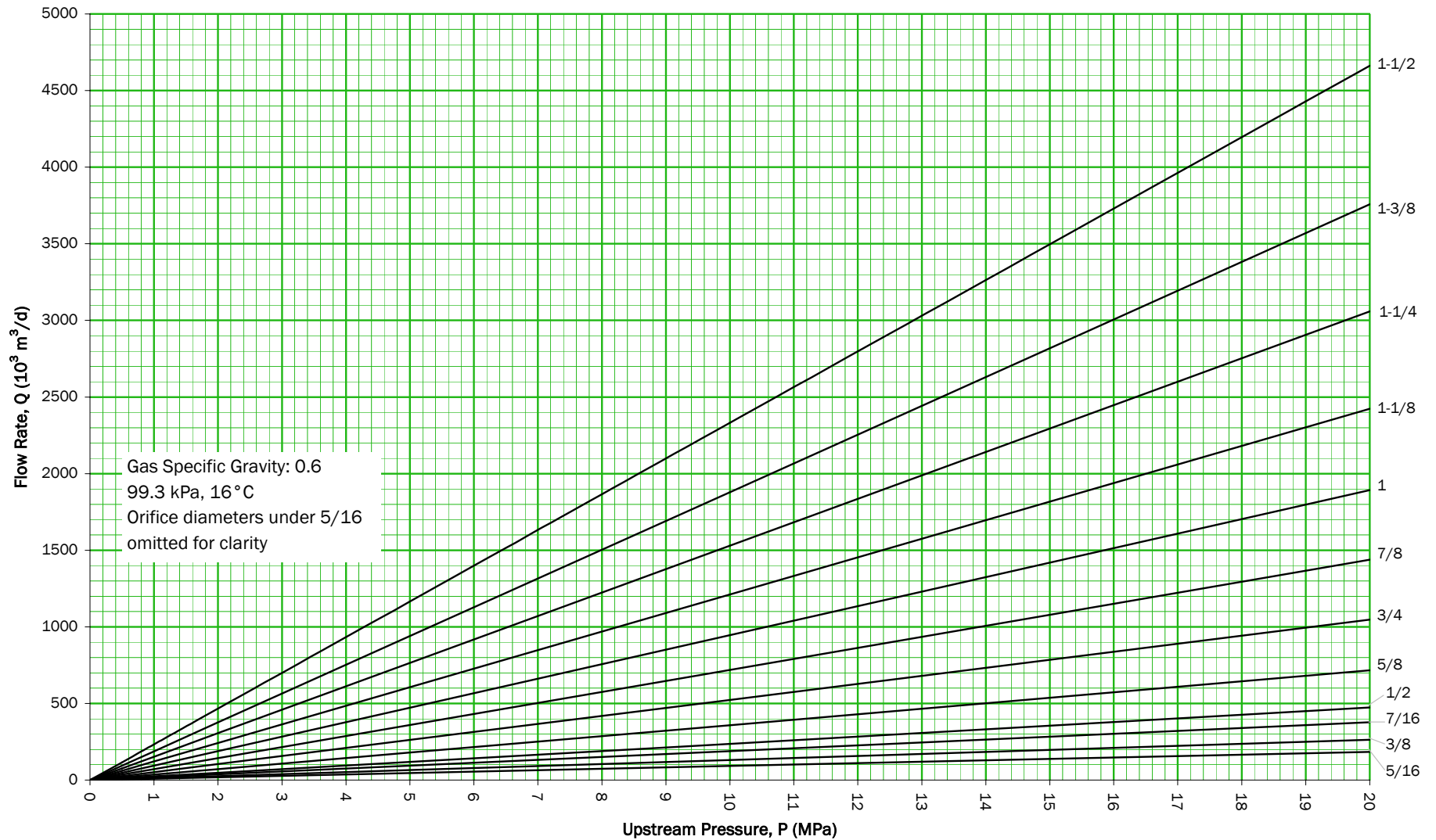

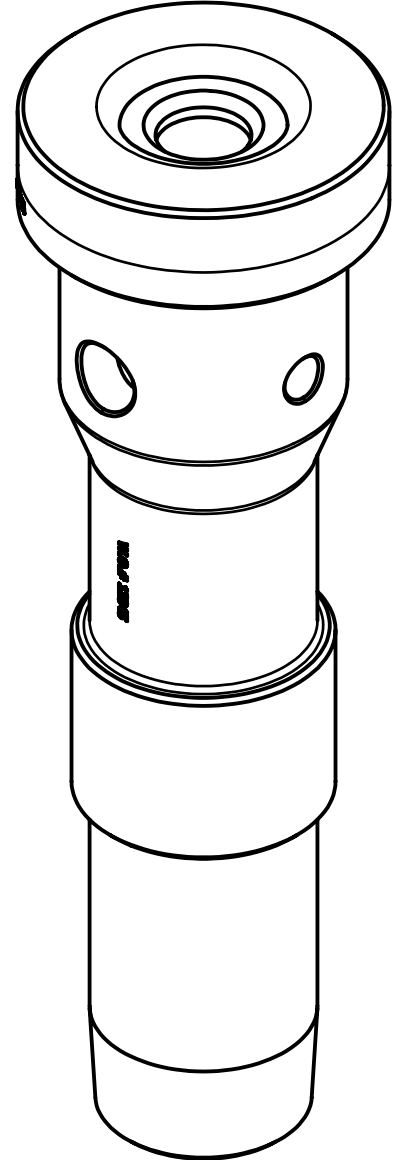
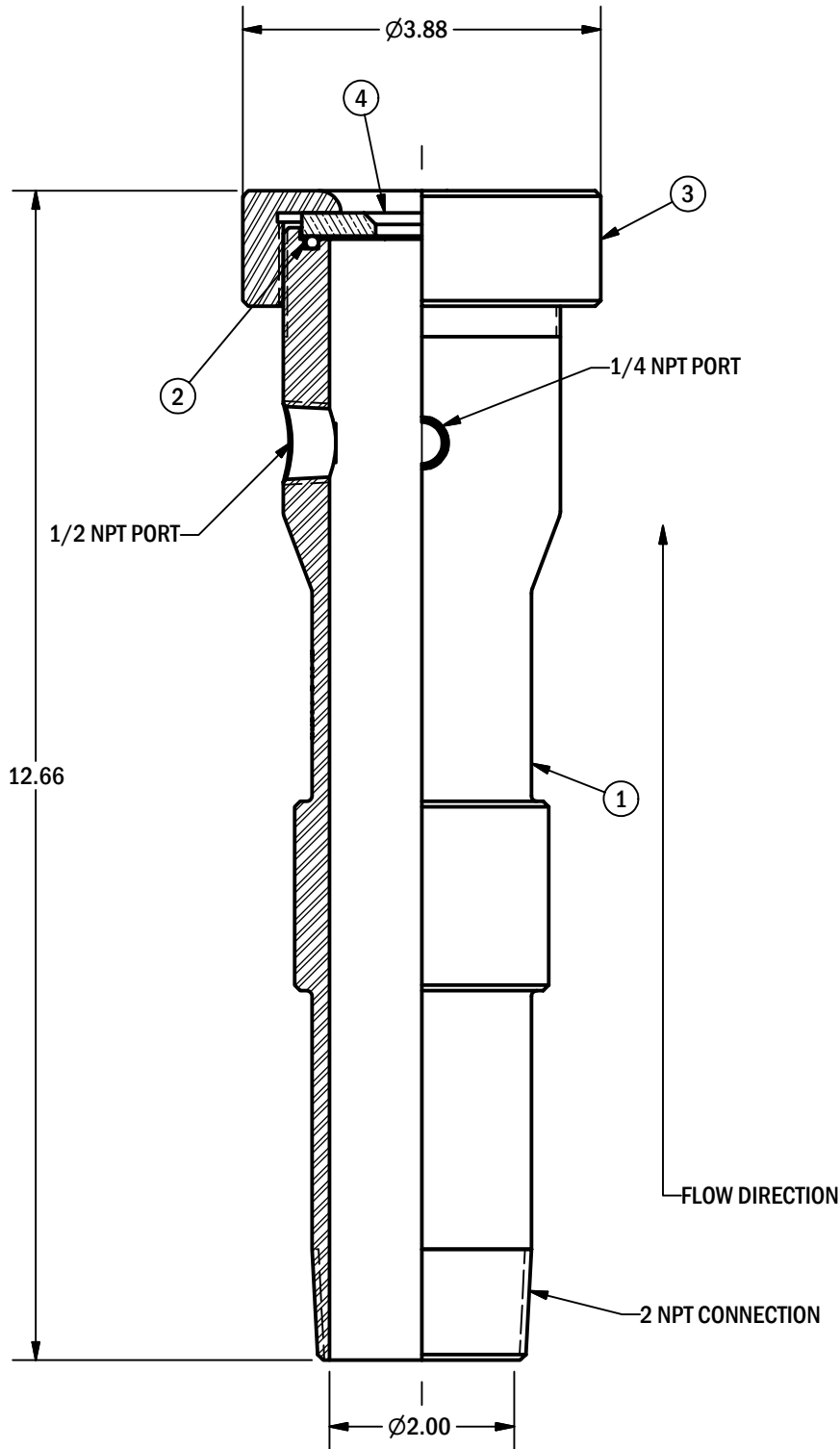

Chart D4: Flow Rate vs. Upstream Pressure (Metric Units)
20 MPa Upstream Pressure, Orifices 5/16 and over



BILL OF MATERIALS		
ITEM	QTY	TITLE
1	1	Flow Prover Body
2	1	O-Ring
3	1	Flow Prover End Cap
4	1	1/4 in. Thk. Orifice Plate

REVISION HISTORY			
REV #	BY	DATE	DESCRIPTION



\\Hawk1.Eng\Manufactured Products\Critical Flow Prover\CFP-200-GD.dwg

TOLERANCES		
DECIMAL	RMS	FRACTIONS
X.X ± 0.050	500	XX-X/X ± 1/16
X.XX ± 0.020	256	X-X/X ± 1/32
X.XXX ± 0.005	128	X/X ± 1/64
T.I.R. ± 0.010 $\leq \pm 1$ THRD ± 1 TURN		
BREAK SHARP EDGES REMOVE ALL BURRS CHAMFER FIRST THREAD A/MATERIAL PREFERRED		
ALL DIMENSIONS IN INCHES		
© 2007 HAWKEYE INDUSTRIES INC.		

PART # CFP-200-ASM	
PARTS REQUIRED	PART IN
NOTICE OF PROPRIETY This document contains confidential and proprietary information of a sensitive nature. The drawing and associated information shall not be disclosed, in whole or in part, or be used to manufacture for use or sale by any party without explicit prior written consent of Hawkeye Industries Inc.	
UNPUBLISHED - CONFIDENTIAL - ALL RIGHTS RESERVED	

MATERIAL A)	BY JH	CHK JH	SCALE 1:2
FINISH / PROCESSING Zinc Dichromate	DATE DRAWN 18-May-07		EST. WEIGHT (LB)
DRAWING NUMBER CFP-200-GD	W.O. #		

HAWKEYE INDUSTRIES INC.
EDMONTON, ALBERTA, CANADA

PROJECT / PRODUCT LINE Critical Flow Prover	DRAWING TITLE General Dimensional Drawing
PART NAME Critical Flow Prover	
PART DESCRIPTION 2", 3000#	
	REV 0